



Better kiosks through intelligent design...

Metropolis Kiosk

Data Sheet

Featuring 19" Wide Viewing Angle Touch Screen and Amplified Stereo Speakers

Sophistication meets simplicity. The sleek contemporary design of this highly customizable retail kiosk makes it the ideal self-service solution for most industries. Our engineers thought of it all, this mighty market kiosk can accommodate more standard and optional components than you can shake a stick at, all in a tidy enclosure. Configure the Metropolis around your needs, around your brand by taking advantage of the generous graphic space. With its variety of hardware configurations, easy service access and large corporate customization space; the Metropolis is a high achiever and remains a popular, cost effective solution.

For more information: info@olea.com

U.S. 800-927-8063

Specifications

- 19" Wide Viewing Angle Touch Screen
- Amplified Stereo Speakers
- Durable Powder Coat Paint Finish
- 16 Gauge Galvanized Steel
- Dual Security Locks
- High Volume Cooling Fan
- ADA Compliant
- Internal 6-outlet power strip w/ surge protection
- Topples resistant base plate with ability to bolt to ground



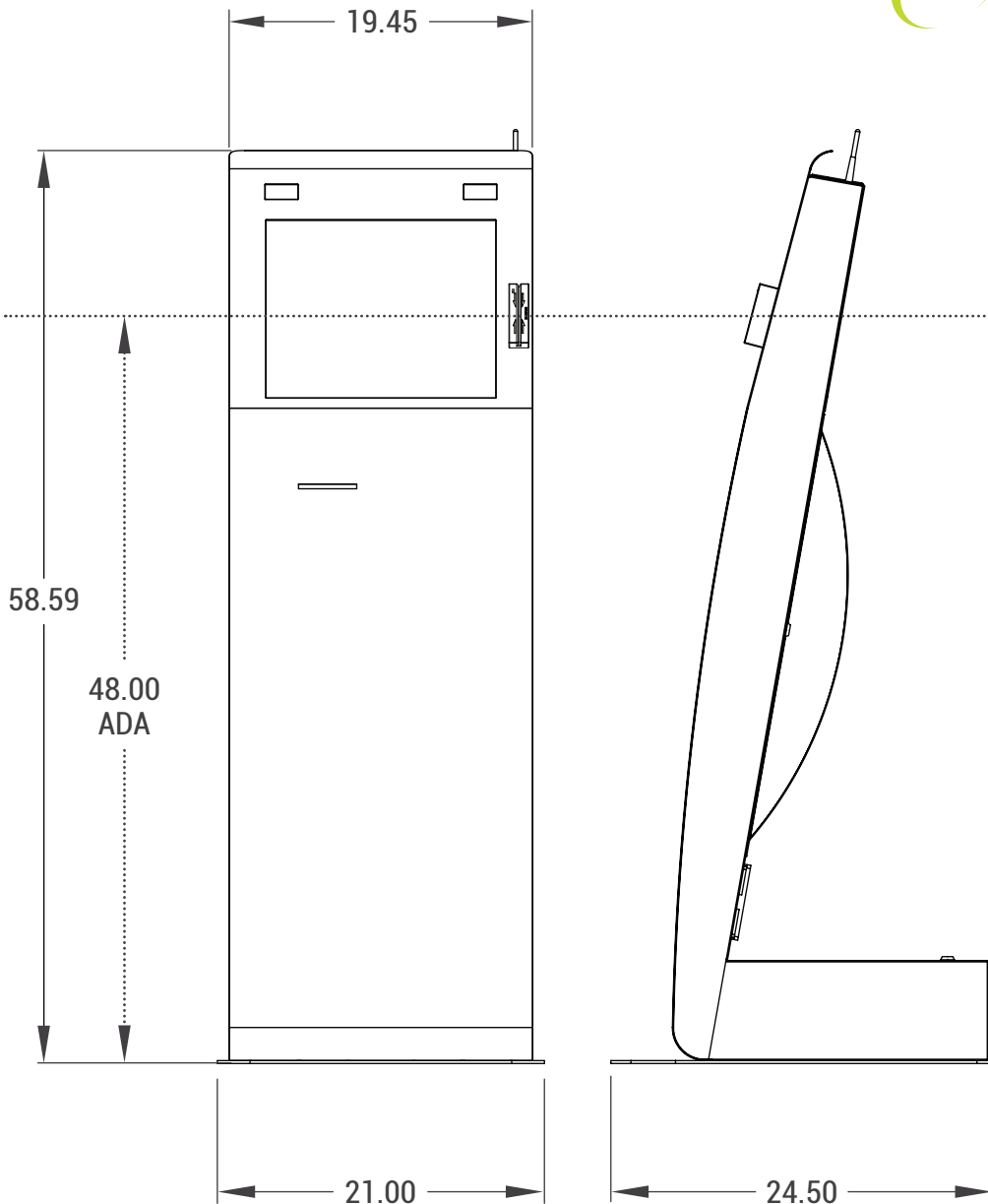

For more information:
info@olea.com
 U.S. 800-927-8063

Dimensions

- Width: 19.45"
- Height: 58.59"
- Depth: 24.50"
- Weight: 127lbs
- Base plate: 21"W x 24.5"D

Optional Components

- Dell Optiplex Business Line PC
- Insert or Swipe Style Credit Card Reader
- Chip and Pin Device
- WiFi or Cellular Connectivity
- Barcode Scanner 1D, 2D, PDF, and QR
- Stainless Steel Keyboard and Trackball
- Web Camera
- Bill Acceptor
- 3M Privacy Filter for Monitor (HIPAA compliant)
- 80mm Thermal Printer (coupon/receipt)
- 8.5" wide Thermal Printer (full sheet)
- 19" Upper Advertising Screen
- 32" Upper Advertising Screen