

**DATA SHEET**

COMPACT FOOTPRINT WITH  
UPPER MESSAGING PANEL

FOR MORE INFORMATION

U.S. 800-927-8063 | [info@olea.com](mailto:info@olea.com)

# BOSTON 2.0 HEALTHCARE KIOSK

After 10 years and thousands of deployments, Olea presents the next generation of our most popular healthcare kiosk. More powerful. More efficient. More Olea.



## BRINGING EXCELLENCE TO THE PATIENT EXPERIENCE

---

- Patient check-in
- Co-pay remittance
- Balance collection
- Personal info updates
- Photo ID
- Biometric scanning
- Insurance-card scanning
- Facility wayfinding
- Scheduling
- And more!





## OLEA KIOSKS

Better Kiosks through Intelligent Design

Forty years and countless customers later, Olea Kiosks has become the one-stop-shop for high-quality, innovative self-service solutions for Fortune 500 companies and smaller brands alike. From QSR giants to the world's leading athletics company, Olea has worked with the best in business.

We manufacture every one of our kiosks at Olea's Los Angeles headquarters while working with clients across the globe to develop innovative solutions that provide the best user-experiences and deliver the highest ROI.



## SOME OF OUR SPECIALTIES

**Healthcare.** The medical profession is still a relative newcomer to self-service. While some kiosks confuse size and cost for excellence, Olea's line of sleek, elegant and small-form-factor units make it easy for facilities of all sizes and budgets to join the EHR revolution and provide a best-in-class patient experience.

**Foodservice.** Competition among QSR and Fast Casual brands is more fierce than ever, all while consumers are demanding more menu choices and better ingredients. Olea's kiosks—inside or at the drive-thru—can increase ROI by driving increased throughput, improving order accuracy and asking for the up-sell with every order.

**Gaming.** As casinos fight to prosper amid changing demographics and player trends, they find themselves adopting new technologies, and Olea Kiosks is leading them into the world of self-service. Our technology helps build brand loyalty, expedite check-in/check-out, bust queues, sell event tickets and more. No wonder casinos from Las Vegas to Macau get their kiosks from us.

**Custom.** Olea Kiosks is known as the "go-to" company for beautifully designed custom kiosks. With decades of experience on hundreds of unique projects, placing over 10,000 specialty units in the market, we feel confident saying we are the industry's leading provider of custom self-service solutions. To earn clients like Nike, Kaiser Permanente and FedEx, you have to be the best.

## THE BOSTON 2.0 HEALTHCARE KIOSK

Small enough to be big. Big enough to be small.

---

The new Boston 2.0 healthcare kiosk is the result of thousands of deployments and millions of patient check-ins. What we learned has made this next generation of our most popular kiosk better in every way.

- Lobby space is prime real estate, so we made sure Boston 2.0 could be placed against walls, in small spaces or back-to-back with other units.
- Front access to all components plus quick-change hardware makes maintenance fast and easy.
- A new 19-inch main monitor with available privacy filter enables onscreen signature capture.
- New LED upper-panel option enables low-power backlit signage opportunities.
- The interior features a new electrical layout with a built-in, secured six-outlet strip.
- All Boston 2.0s ship ready to accept the latest EMV payment technology.

Of course, like all Olea kiosks, Boston 2.0 is fully ADA-compliant.

The standard components, including capacitive touch technology with accurate onscreen signature capture, EMV-readiness, duplex ID scanner and printer, are all designed for easy access by all patients. Optional components include a barcode scanner, web camera, Wi-Fi adapter and audio headphone jack.

Boston 2.0 is fully compatible with EHR products from Epic, Siemens, McKesson and others.



## A CLOSER LOOK AT BOSTON 2.0



The easy-access front panel makes maintenance fast and easy.

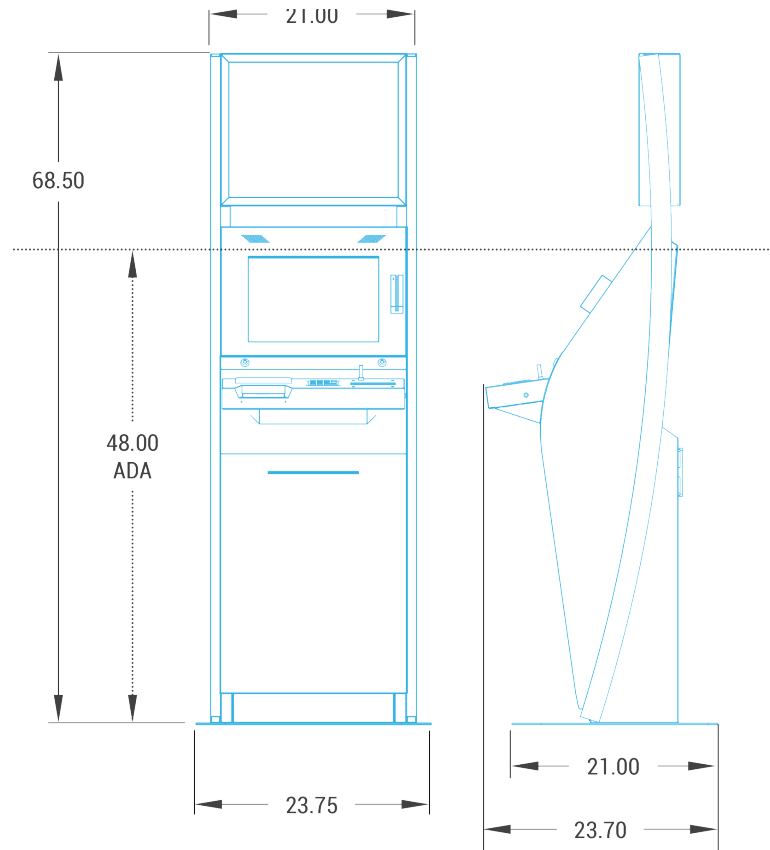

### STANDARD

- Complete overhaul for today's most demanding standards
- New 19" Elo IntelliTouch (SAW) touchscreen with privacy filter
- Expanded internal space for added components and maintenance ease
- Recessed touchscreen for added privacy
- Barcode scanner
- Magnetic card reader
- Electronic signature pad
- Graphic light box
- 8.5" thermal printer
- Speakers
- High-volume cooling fan
- Audio jack

### OPTIONAL

- Wi-Fi connectivity
- Web camera
- LCD monitor for upper signage
- Stainless trackball
- Biometric ID device (fingerprint, iris or palm)

### DIMENSIONS

- Width: 21"
- Height: 68.50"
- Depth: 23.70"
- Weight: 164lbs
- Base plate: 23.75"w x 21"d