



Better kiosks through intelligent design...

Metrolite 22 Wide Kiosk

Data Sheet



Featuring a 22" Touch Screen, Small Footprint, and Amplified Stereo Speakers

Designed to impress, the modern and adaptable Metrolite Wide 22 continues Olea's mission to provide better kiosks through intelligent design. Preserving the flexible configuration found in all Olea products, this kiosk's precision engineering accommodates features such as credit card reader, keyboard, trackball, receipt printer and Wi-Fi capability. The multitude of transactional components featured in the Metrolite Wide 22 makes it one of the most powerful retail solutions available on the market. Companies that seek to improve user interaction and ROI in small spaces or high traffic can depend on its compact footprint and dynamic security constituents.

For more information: info@olea.com

U.S. 800-927-8063

Specifications

- 22" wide viewing angle touch screen
- Available in 16:9 or 16:10 format
- ADA Compliant
- Security Locks
- Durable Powder Coat Paint Finish
- 16 Gauge Galvanized Steel
- High Volume Cooling Fan
- Amplified Stereo Speakers
- Internal 6-outlet power strip w/ surge protection
- Topples-resistant base plate with ability to bolt to ground



Optional Components

- Dell Optiplex Business Line PC
- Insert or Swipe Style Credit Card Reader
- WiFi or Cellular Connectivity
- Barcode Scanner 1D, 2D, PDF, and QR
- 3M Privacy Filter for Monitor (HIPAA compliant)
- 80mm Thermal Printer (coupon/receipt)
- Stainless Steel Keyboard and Trackball

Dimensions

- Width: 22.37"
- Height: 55.25"
- Depth: 19.88"
- Base plate: 26.50"W x 19.88"
- Weight: 142 lbs.

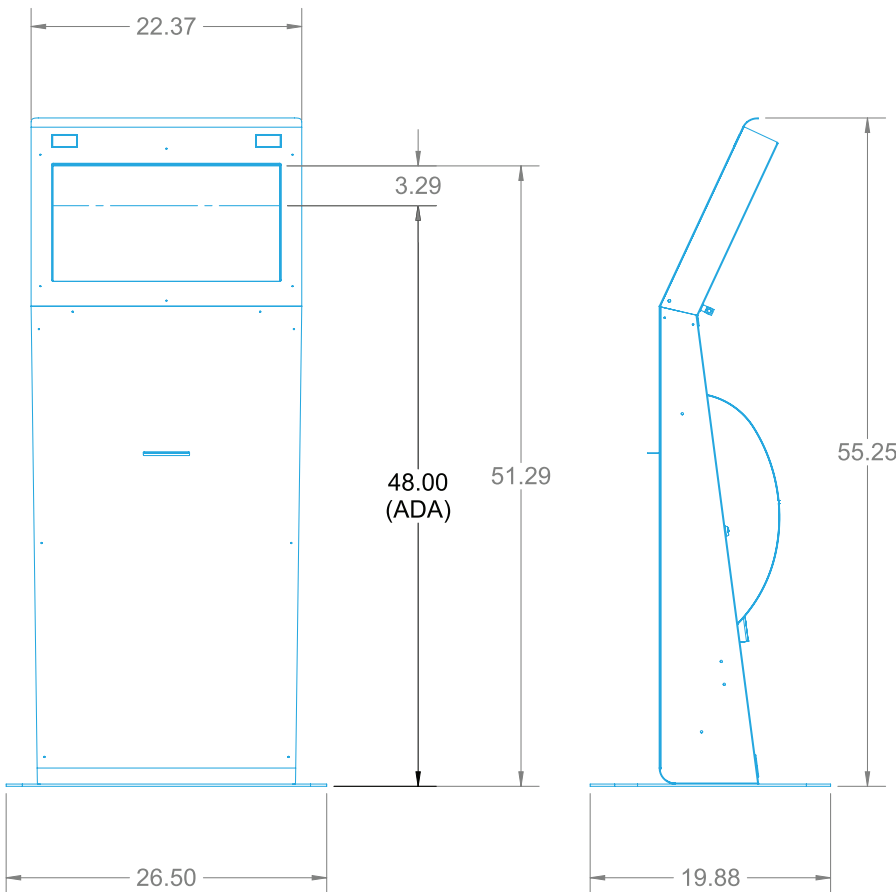

For more information:
info@olea.com
U.S. 800-927-8063