

METROLITE KIOSK

DATA SHEET MODERN AND ADAPTABLE

Simple, modern, and Impactful.

The Metrolite has become one of the most recognizable kiosk designs in the world. Born out of necessity, it is an impactful solution that doesn't require much space.

The eye-catching design demands attention and the hundreds of available configurations meet almost every need. The Metrolite is designed to make deploying kiosks simple, efficient, and successful from day one..

BRINGING EXCELLENCE TO THE GUEST EXPERIENCE

- Self-Check Out
- Retail Transactions
- Food Ordering
- Ticketing
- Check-In
- Wayfinding
- Employee Onboarding
- Job Applications



METROLITE KIOSK

FEATURING A SMALL FOOTPRINT, 19" TOUCH SCREEN AND AMPLIFIED STEREO SPEAKERS



Modern and adaptable, this kiosk is designed to impress; the Metrolite continues Olea's mission to provide better kiosks through intelligent design.

To maintain the flexible configuration all of our kiosks boast, the Metrolite was meticulously engineered to accommodate optional credit card reader, receipt printer, keyboard, barcode scanner and more.

The wide array of transactional components housed in this sleek, feature-packed kiosk makes it one of the most powerful retail solutions available on the market.

Its compact footprint and rugged security compliment a variety of environments for companies that seek to improve ROI and user interaction in small spaces or high traffic areas.

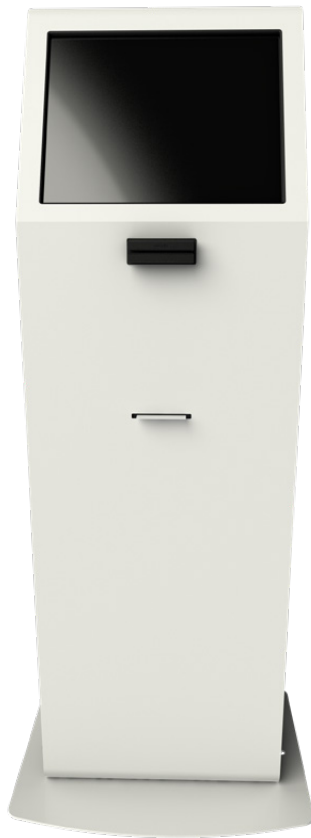

A CLOSER LOOK

AT METROLITE KIOSK

STANDARD SPECS

- 19" Wide Viewing Angle Touch Screen
- Amplified Stereo Speakers
- Durable powder coat paint finish
- 16 Gauge galvanized steel
- Security locks
- High volume cooling fan
- ADA compliant
- Internal 6-outlet power strip w/ surge protection
- Topple resistant base plate with ability to bolt to ground

DIMENSIONS

- Width: 22.37"
- Height: 55.25"
- Depth: 19.88"
- Weight: 99lbs
- Base plate: 26.50"w x 19.88"d

OPTIONAL COMPONENTS

- Dell Optiplex Business Line PC
- Insert or swipe-style card reader
- Wi-Fi or cellular connectivity
- Barcode scanner (1D, 2D, PDF and QR)
- 3M privacy filter for monitor (HIPAA compliant)
- 80mm thermal printer (coupons/receipts)
- Stainless steel keyboard and trackball

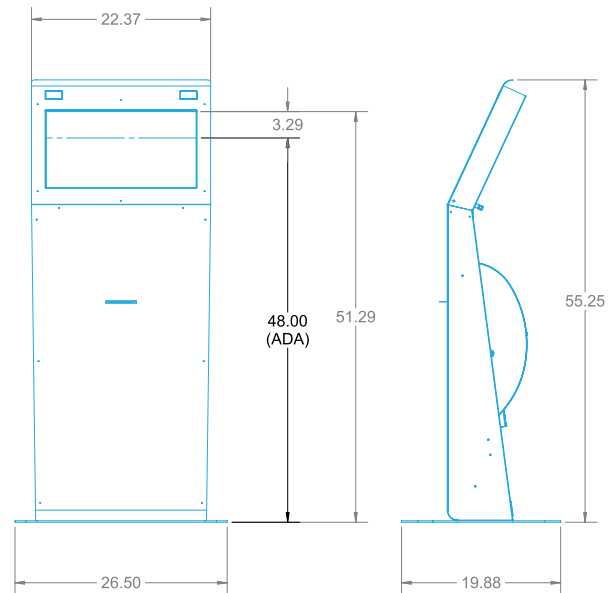

REDEFINING SELF-SERVICE TECHNOLOGY

ABOUT OLEA KIOSKS

CONTINUING A PROUD HERITAGE OF EXCELLENCE

Inspired by a true passion for his craft, master carpenter Fernando Olea began a tradition of bringing his customers' ideas to life back in 1975. He started designing, engineering and producing furniture, cabinetry, display exhibits, commissioned works of art and, later, kiosks in his small, rented RV garage in Downey, California. And Olea was born.

From those humble beginnings to the company's current high-capacity manufacturing facility in Southern California, Olea Kiosks continues to be driven by our founder's innovative spirit, with an old-fashioned commitment to quality, craftsmanship, and service. More than 40 years later our network of 35,000 kiosks registers over 100 million touchpoints per year and we remain a family-owned and operated company. Olea continues to push the limits of kiosk design, using our curiosity and intuition to find new self-service solutions that create a lasting impact for our customers.

AN UNPARALLELED COMMITMENT TO QUALITY AND SERVICE

At Olea, we go beyond producing kiosks that simply meet your technical requirements. We engineer self-service solutions that enhance our clients' brands and complement any space where they are implemented. The following in-house departments work together to consistently deliver attentive customer service and innovative kiosks that comply with our strict quality control guidelines.

- Consulting
- Industrial Design
- Creative Consulting and Graphic Creation
- Mechanical and Structural Engineering
- OEM Manufacturing
- Integration Services
- IT Department (for product testing, computer ghosting services and hardware selection/consulting)
- Powder Coat Painting
- Certification Services
- Patent Services

