

MONTE CARLO GAMING KIOSK

DATA SHEET

VERSATILE APPROACH TO THE PLAYER EXPERIENCE

A modern approach to the player experience

Our latest winning kiosk for casinos features card-printing and vibrant LED lighting that can be controlled remotely or programmed, and its sleek design fits in any décor.

The Monte Carlo boasts robust components that stand up to 24/7 use. Two large LCD panels create a rewarding touch experience for users, while the highly visible digital signage is perfect for advertising, wayfinding and more.

BRINGING EXCELLENCE TO THE GUEST EXPERIENCE

- Casino Loyalty
- Retail
- Transactions
- Wayfinding
- Healthcare
- Human Resources
- Information
- Check-In
- Casino
- Transportation



THE MONTE CARLO GAMING KIOSK

THE MODERN APPROACH TO THE PLAYER EXPERIENCE

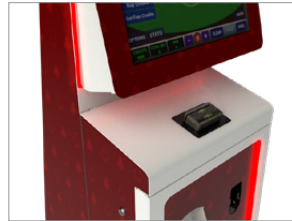
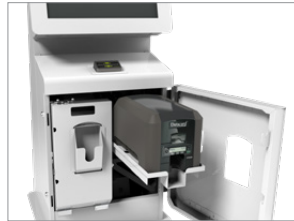

Featuring two large displays for touch and for digital signage applications.

From managing loyalty programs and resort rewards, to queue-busting and self-check / check-out, the Monte Carlo Gaming Kiosk performs as great as it looks.

Our latest winner for casinos features card-printing and vibrant LED lighting that can be controlled remotely or programmed, and its sleek design fits in any decor, in any use across the casinos/ resort property.

Robust components stand up to 24/7 use, even in smoking areas, while two large LCD panels create a rewarding touch experience for users and highly visible digital signage for advertising, wayfinding and more.



A CLOSER LOOK

AT MONTE CARLO GAMING

STANDARD SPECS

- 22" touchscreen (16:9 or 16:10)
- 22" LCD upper display monitor
- LED attract lighting
- Front-service access door
- Dual security locks
- Durable powder coat paint finish
- High-volume cooling fan
- Topple-resistant base plate with ability to bolt to ground

STANDARD SPECS

- Width: 24"
- Height: 63.531"
- Depth: 23.679"
- Base plate: 25"w x 23.679"D
- Weight: 164lbs..

OPTIONAL COMPONENTS

- Ithaca Epic 950 printer
- Ticket printer
- Driver's license scanner
- DataCard CD800 card printer with open-card format
- PC with service keyboard
- 80mm thermal printer (coupon/receipt)
- Stainless steel keyboard and trackball
- Swipe-style credit card reader
- WiFi or cellular connectivity

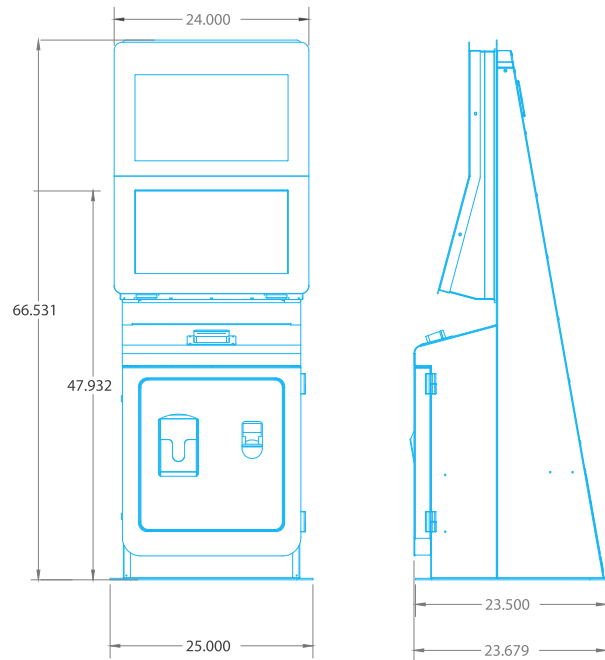

REDEFINING SELF-SERVICE TECHNOLOGY

ABOUT OLEA KIOSKS

CONTINUING A PROUD HERITAGE OF EXCELLENCE

Inspired by a true passion for his craft, master carpenter Fernando Olea began a tradition of bringing his customers' ideas to life back in 1975. He started designing, engineering and producing furniture, cabinetry, display exhibits, commissioned works of art and, later, kiosks in his small, rented RV garage in Downey, California. And Olea was born.

From those humble beginnings to the company's current high-capacity manufacturing facility in Southern California, Olea Kiosks continues to be driven by our founder's innovative spirit, with an old-fashioned commitment to quality, craftsmanship, and service. More than 40 years later our network of 35,000 kiosks registers over 100 million touchpoints per year and we remain a family-owned and operated company. Olea continues to push the limits of kiosk design, using our curiosity and intuition to find new self-service solutions that create a lasting impact for our customers.

AN UNPARALLELED COMMITMENT TO QUALITY AND SERVICE

At Olea, we go beyond producing kiosks that simply meet your technical requirements. We engineer self-service solutions that enhance our clients' brands and complement any space where they are implemented. The following in-house departments work together to consistently deliver attentive customer service and innovative kiosks that comply with our strict quality control guidelines.

- Consulting
- Industrial Design
- Creative Consulting and Graphic Creation
- Mechanical and Structural Engineering
- OEM Manufacturing
- Integration Services
- IT Department (for product testing, computer ghosting services and hardware selection/consulting)
- Powder Coat Painting
- Certification Services
- Patent Services

