

# VERONA KIOSK

## DATA SHEET MULTI-FUNCTION HEALTHCARE KIOSK

*Push-button for easy up/down height adjustment.*

With the press of a button, the ADA-compliant Verona can raise and lower over a 10-inch range, providing easy access for all patients, standing or sitting.

The Verona is equipped with standard and optional components to complete any healthcare check-in or related task, including privacy filters for data protection, thermal printer for receipts, instructions, maps and more.

## BRINGING EXCELLENCE TO THE GUEST EXPERIENCE

- Patient check-in
- Balance collection
- Photo ID
- Insurance-card scanning
- Scheduling
- Co-pay remittance
- Personal info updates
- Biometric scanning
- Facility wayfinding



# THE VERONA KIOSK

## ADA COMPLIANCE WITH DIRECT ROLL-UP WHEELCHAIR ACCESS

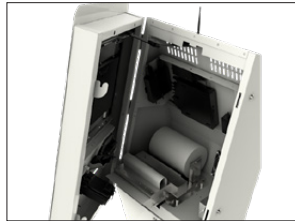

The Verona is a fully ADA-compliant, adjustable-height patient healthcare kiosk solution.

With the press of a button, the Verona can raise and lower over a 10-inch range, providing easy access for all patients, standing or sitting. The extended front console accommodates wheelchair users and is compliant with forward-approach ADA requirements as well as HIPAA privacy regulations.



The standard components, including capacitive touch technology with accurate onscreen signature capture, EMV-readiness, duplex ID scanner and printer, are all designed for easy use by all patients. Optional components include a barcode scanner, web camera, Wi-Fi adapter, audio headphone jack and 8.5" thermal printer.

Built with serviceability in mind, the quick-change hardware system can be accessed and serviced easily and efficiently. All internal systems of the Verona are accessible through the front of the unit, making it perfect for placement against a wall or with another Verona unit back-to-back. A true turnkey solution for providers, the Verona is fully compatible with EHR products from Epic, Siemens, McKesson and others.



# A CLOSER LOOK

## AT VERONA HEALTHCARE

### STANDARD SPECS

- 19" ELO projected capacitive touchscreen with privacy filter
- Push-button height adjustable over true 10-inch vertical range
- Image ID scanner
- EMV payment devices
- 8.5" thermal printer.
- Speakers
- Web camera
- Audio jack

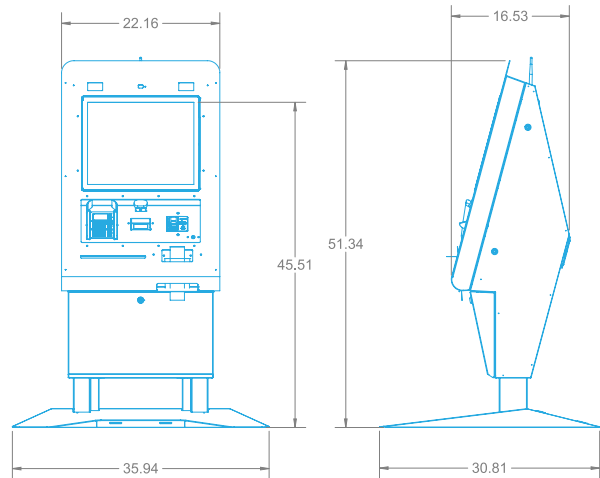

### STANDARD SPECS

- Width: 22.16"
- Min Height: 51.34"
- Max Height: 61.84"
- Depth: 16.53"
- Base plate: 35.94" w x 30.81"
- Weight: 127lbs.

### OPTIONAL COMPONENTS

- Magnetic card reader (swipe or dip)
- Biometric identification device (fingerprint, iris or palm)
- WiFi or cellular connectivity

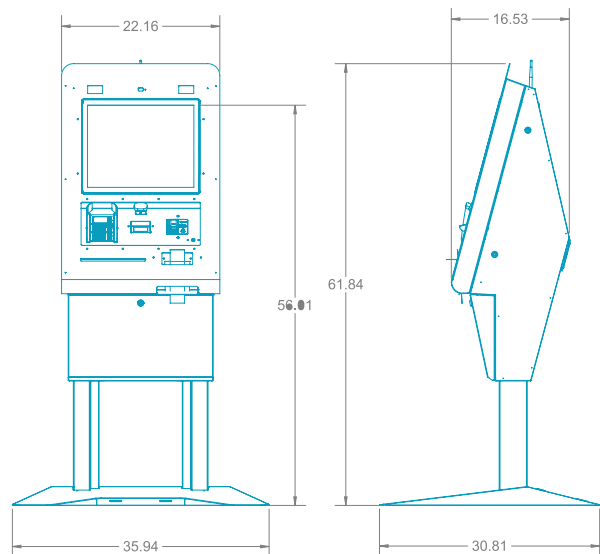

# REDEFINING SELF-SERVICE TECHNOLOGY

## ABOUT OLEA KIOSKS

### CONTINUING A PROUD HERITAGE OF EXCELLENCE

Inspired by a true passion for his craft, master carpenter Fernando Olea began a tradition of bringing his customers' ideas to life back in 1975. He started designing, engineering and producing furniture, cabinetry, display exhibits, commissioned works of art and, later, kiosks in his small, rented RV garage in Downey, California. And Olea was born.

From those humble beginnings to the company's current high-capacity manufacturing facility in Southern California, Olea Kiosks continues to be driven by our founder's innovative spirit, with an old-fashioned commitment to quality, craftsmanship, and service. More than 40 years later our network of 35,000 kiosks registers over 100 million touchpoints per year and we remain a family-owned and operated company. Olea continues to push the limits of kiosk design, using our curiosity and intuition to find new self-service solutions that create a lasting impact for our customers.

### AN UNPARALLELED COMMITMENT TO QUALITY AND SERVICE

At Olea, we go beyond producing kiosks that simply meet your technical requirements. We engineer self-service solutions that enhance our clients' brands and complement any space where they are implemented. The following in-house departments work together to consistently deliver attentive customer service and innovative kiosks that comply with our strict quality control guidelines.

- Consulting
- Industrial Design
- Creative Consulting and Graphic Creation
- Mechanical and Structural Engineering
- OEM Manufacturing
- Integration Services
- IT Department (for product testing, computer ghosting services and hardware selection/consulting)
- Powder Coat Painting
- Certification Services
- Patent Services

