

# CALIFORNIA CYBER SECURITY KIOSK

## DATA SHEET PORTABLE MEDIA CYBER SECURITY KIOSK

*Protect against portable media threats*

The Olea Portable Media Cyber Security Kiosk is designed to help companies safeguard their infrastructure from malware threats on removable devices brought in by employees, contractors, vendors and others.

Using OPSWAT's Metascan multi-scanning technology, Olea's kiosk can scan USB drives, Blu-ray/CDs/DVDs, and other portable media using up to 30 fully-licensed antivirus engines.

## BRINGING EXCELLENCE TO THE INDUSTRIES

- Financial
- Nuclear
- Government
- Utilities
- Healthcare
- Energy



# CALIFORNIA CYBER SECURITY KIOSK

FEATURING 30 ANTI-VIRUS ENGINES, 15-IN-1 MEDIA READER AND ENHANCED DELL CPU

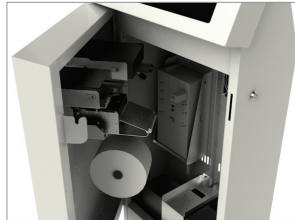

The modern design is complimented by an array of features such as a 15-in-1 media reader, a receipt printer, a robust Dell CPU, 2 external USB ports and a UPS Battery device that continues power during an electrical brownout.



Top tier components and robust software are housed in a stylish and cost effective security scanning terminal with a compact footprint. Sophisticated performance in a compact enclosure; this kiosk provides the ultimate turnkey cyber security solution.



# A CLOSER LOOK

## AT CALIFORNIA CYBER SECURITY

### STANDARD SPECS

- 19" ELO SAW touchscreen
- 15-in-1 media reader
- 2 USB external connectors
- DVD/ Blue-ray / CD reader
- UPS battery device
- 16 gauge galvanized steel
- Amplified stereo speakers
- Durable powder coat paint finish
- Dual security locks
- High volume cooling fan
- ADA compliant
- Internal 6-outlet power strip with surge protection
- Topple resistant base plate with ability to bolt to ground

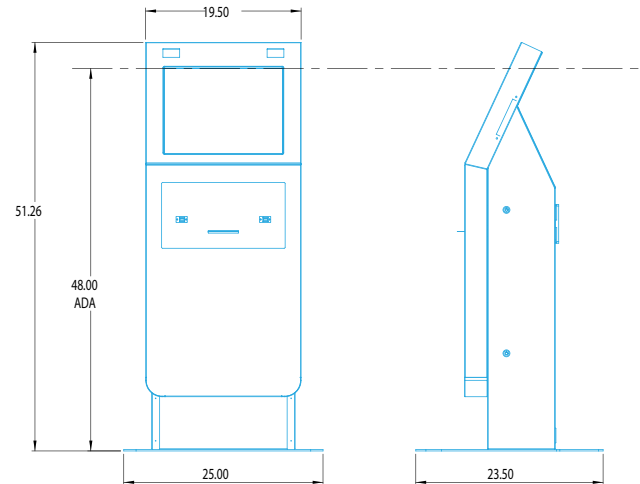

### DIMENSIONS

- Width: 19.45"
- Height: 51.21"
- Depth: 23.50"
- Base plate: 25"w x 23.5"d

### OPTIONAL COMPONENTS

- 80mm thermal printer (receipt)
- Floppy drive
- Swipe style credit card reader
- Dell PC
- Stainless keyboard and trackball
- WiFi or cellular connectivity

# REDEFINING SELF-SERVICE TECHNOLOGY

## ABOUT OLEA KIOSKS

### CONTINUING A PROUD HERITAGE OF EXCELLENCE

Inspired by a true passion for his craft, master carpenter Fernando Olea began a tradition of bringing his customers' ideas to life back in 1975. He started designing, engineering and producing furniture, cabinetry, display exhibits, commissioned works of art and, later, kiosks in his small, rented RV garage in Downey, California. And Olea was born.

From those humble beginnings to the company's current high-capacity manufacturing facility in Southern California, Olea Kiosks continues to be driven by our founder's innovative spirit, with an old-fashioned commitment to quality, craftsmanship, and service. More than 40 years later our network of 35,000 kiosks registers over 100 million touchpoints per year and we remain a family-owned and operated company. Olea continues to push the limits of kiosk design, using our curiosity and intuition to find new self-service solutions that create a lasting impact for our customers.

### AN UNPARALLELED COMMITMENT TO QUALITY AND SERVICE

At Olea, we go beyond producing kiosks that simply meet your technical requirements. We engineer self-service solutions that enhance our clients' brands and complement any space where they are implemented. The following in-house departments work together to consistently deliver attentive customer service and innovative kiosks that comply with our strict quality control guidelines.

- Consulting
- Industrial Design
- Creative Consulting and Graphic Creation
- Mechanical and Structural Engineering
- OEM Manufacturing
- Integration Services
- IT Department (for product testing, computer ghosting services and hardware selection/consulting)
- Powder Coat Painting
- Certification Services
- Patent Services

