

# METROPOLIS KIOSK

## DATA SHEET

### MAXIMUM FLEXIBILITY; MINIMAL FOOTPRINT

*Highly Customizable Touchscreen Retail Kiosk*

Sophistication meets simplicity. The sleek contemporary design of this highly customizable retail kiosk makes it the ideal self-service solution for most industries..

## BRINGING EXCELLENCE TO THE GUEST EXPERIENCE

- Retail Transactions
- Ticketing
- Wayfinding
- Donations Kiosks
- Healthcare
- Human Resource
- Information
- Check-In
- Casino Loyalty
- Transportation
- Bill Payment



# METROPOLIS KIOSK

**FEATURING 19" WIDE ANGLE TOUCH SCREEN AND AMPLIFIED STEREO SPEAKERS**



Sophistication meets simplicity. The sleek contemporary design of this highly customizable retail kiosk makes it the ideal self-service solution for most industries.



Our engineers thought of it all, this mighty market kiosk can accommodate more standard and optional components than you can shake a stick at, all in a tidy enclosure.

Configure the Metropolis around your needs, around your brand by taking advantage of the generous graphic space.

With its variety of hardware configurations, easy service access and large corporate customization space; the Metropolis is a high achiever and remains a popular, cost effective solution.



# A CLOSER LOOK

## AT METROPOLIS KIOSK

### STANDARD SPECS

- 19" Wide viewing angle touchscreen
- Amplified stereo speakers
- Durable powder coat paint finish
- 16 gauge galvanized steel
- Dual security locks
- High volume cooling fan
- ADA-compliant
- Internal 6-outlet power strip w/surge protection
- Topple-resistant base plate with ability to bolt to ground

### DIMENSIONS

- Width: 19.5"
- Height: 58.59"
- Depth: 24.50"
- Base plate: 21"w x 24.50"d

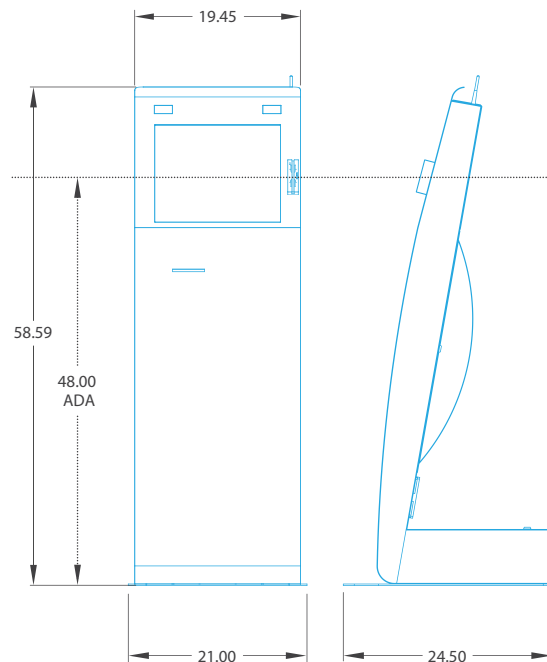

### OPTIONAL COMPONENTS

- Dell Optiplex Business Line PC
- Insert or swipe-style card reader
- Chip and pin device
- Wi-Fi or cellular connection
- Barcode scanner (1D, 2D, PDF and QR)
- Stainless steel keyboard and trackball
- Web camera
- Up to 1000 - Note Bill Acceptor
- 3M privacy filter for monitor (HIPAA compliant)
- 80mm thermal printer (coupon/receipt)
- 8.5" wide thermal printer (full sheet)
- 19" upper advertising screen
- 32" upper advertising screen

# REDEFINING SELF-SERVICE TECHNOLOGY

## ABOUT OLEA KIOSKS

### CONTINUING A PROUD HERITAGE OF EXCELLENCE

Inspired by a true passion for his craft, master carpenter Fernando Olea began a tradition of bringing his customers' ideas to life back in 1975. He started designing, engineering and producing furniture, cabinetry, display exhibits, commissioned works of art and, later, kiosks in his small, rented RV garage in Downey, California. And Olea was born.

From those humble beginnings to the company's current high-capacity manufacturing facility in Southern California, Olea Kiosks continues to be driven by our founder's innovative spirit, with an old-fashioned commitment to quality, craftsmanship, and service. More than 40 years later our network of 35,000 kiosks registers over 100 million touchpoints per year and we remain a family-owned and operated company. Olea continues to push the limits of kiosk design, using our curiosity and intuition to find new self-service solutions that create a lasting impact for our customers.

### AN UNPARALLELED COMMITMENT TO QUALITY AND SERVICE

At Olea, we go beyond producing kiosks that simply meet your technical requirements. We engineer self-service solutions that enhance our clients' brands and complement any space where they are implemented. The following in-house departments work together to consistently deliver attentive customer service and innovative kiosks that comply with our strict quality control guidelines.

- Consulting
- Industrial Design
- Creative Consulting and Graphic Creation
- Mechanical and Structural Engineering
- OEM Manufacturing
- Integration Services
- IT Department (for product testing, computer ghosting services and hardware selection/consulting)
- Powder Coat Painting
- Certification Services
- Patent Services

