

# AUSTIN DESKTOP

## DATA SHEET COMPACT AND VERSATILE

*Small size enclosure, full-size functionality.*

Invite your customers to a place they're familiar with, the counter. Enjoy the same functionality and components as the freestanding model with a refreshing touch on a familiar concept.

Don't skip a beat with getting your customers to switch to self-service. The compact footprint easily fits on your counter without absorbing much of the valuable space.

The Austin Desktop is likely one of the greater designs Olea has come forth with in our 40 years of solution development. Often times it's hard to create a compact solution without sacrificing serviceability and functionality. This desktop evades that notion perfectly.



## BRINGING EXCELLENCE TO THE GUEST EXPERIENCE

- Food ordering
- Ticketing
- Information
- Check-in / Check-out
- Wayfinding
- Virtual receptionist
- Retail transactions
- Bill payment

# AUSTIN DESKTOP KIOSK

**SLEEK & MODERN. THE AUSTIN KIOSK CAN WORK IN ALMOST ANY ENVIRONMENT**



The Austin Desktop is a small-size enclosure with full-size functionality. When construction isn't an option and space is limited, repurpose the front counter for self-service instead. That said, don't sacrifice your flexibility when it comes to hardware options:

The monitor can be ordered in portrait or landscape orientation. Both 15" and 22" PCAP touchscreens are available.

The kiosk is serviced from the front-side, making it easy to get in-and-out quickly when routine maintenance is needed.

The kiosk utilizes familiar POS receipt printers so that no kiosk-specific receipt paper needs to be ordered and stocked.

Several payment device options are already available and more are added as needed.



# A CLOSER LOOK

## AT AUSTIN DESKTOP

### STANDARD SPECS

- 5" or 22" All in One Computer
- Projective capacitive multi-touch touch sensor
- Durable powder coat paint finish
- 16 Gauge Galvanized Steel
- Security Locks
- Internal 6-outlet power strip w/ surge protection
- Topple resistant base plate with ability to bolt to ground

### DIMENSIONS

#### Landscape Dimensions

- Width: 24.08"
- Height: 25.99"
- Depth: 15"
- Base plate: 16"w x 15"D

#### Portrait Dimensions

- Width: 16.21"
- Height: 28.34"
- Depth: 15"
- Base plate: 16"w x 15"D

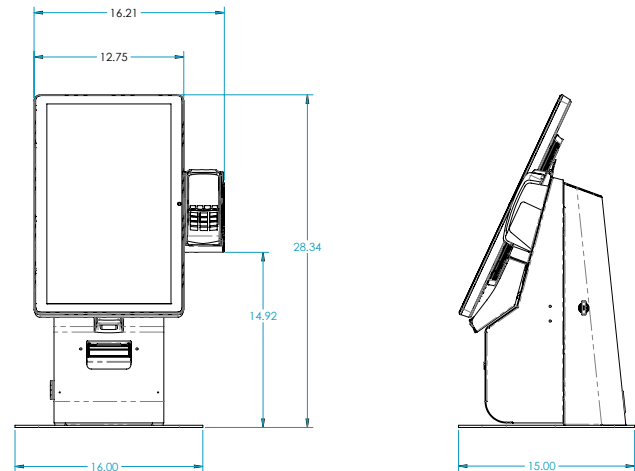
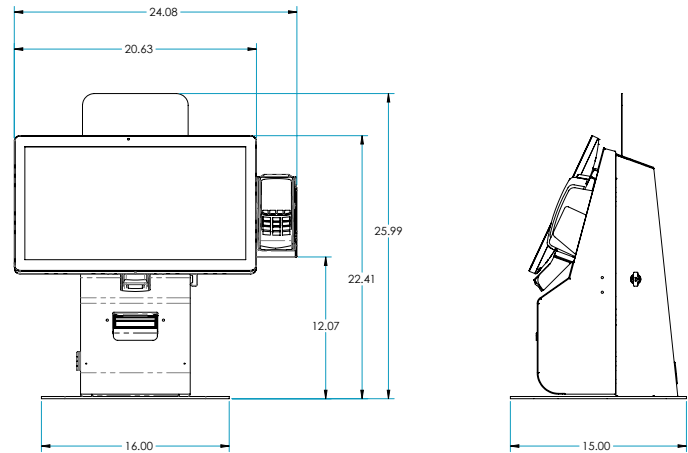

### OPTIONAL COMPONENTS

- 15" or 22" All in One Multi-Touch Computer (PCAP)
- Ingenico and Verifone payment devices
- Epson TM-t88VI receipt printer
- Star Micronics TSP650II
- Barcode Scanner 1D, 2D, PDF, and QR
- ID Card Scanner
- Loyalty / gift card scanner

# REDEFINING SELF-SERVICE TECHNOLOGY

## ABOUT OLEA KIOSKS

### CONTINUING A PROUD HERITAGE OF EXCELLENCE

Inspired by a true passion for his craft, master carpenter Fernando Olea began a tradition of bringing his customers' ideas to life back in 1975. He started designing, engineering and producing furniture, cabinetry, display exhibits, commissioned works of art and, later, kiosks in his small, rented RV garage in Downey, California. And Olea was born.

From those humble beginnings to the company's current high-capacity manufacturing facility in Southern California, Olea Kiosks continues to be driven by our founder's innovative spirit, with an old-fashioned commitment to quality, craftsmanship, and service. More than 40 years later our network of 35,000 kiosks registers over 100 million touchpoints per year and we remain a family-owned and operated company. Olea continues to push the limits of kiosk design, using our curiosity and intuition to find new self-service solutions that create a lasting impact for our customers.

### AN UNPARALLELED COMMITMENT TO QUALITY AND SERVICE

At Olea, we go beyond producing kiosks that simply meet your technical requirements. We engineer self-service solutions that enhance our clients' brands and complement any space where they are implemented. The following in-house departments work together to consistently deliver attentive customer service and innovative kiosks that comply with our strict quality control guidelines.

- Consulting
- Industrial Design
- Creative Consulting and Graphic Creation
- Mechanical and Structural Engineering
- OEM Manufacturing
- Integration Services
- IT Department (for product testing, computer ghosting services and hardware selection/consulting)
- Powder Coat Painting
- Certification Services
- Patent Services

