

BOSTON HEALTHCARE KIOSK

DATA SHEET INTERACTIVE KIOSK BUILT FOR PRIVACY

Advertising space in a multi-function, ADA-Compliant

Increase user traffic with this well-rounded and elegantly designed interactive kiosk. The Boston was engineered to address privacy, user comfort and maximize ROI.

The Boston boasts an optional recessed monitor and 3M Privacy Filter that enhances close viewing but deters shoulder surfing. It also makes changing paper a snap with the front service access door.

BRINGING EXCELLENCE TO THE GUEST EXPERIENCE

- Patient check-in
- Co-pay remittance
- Balance collection
- Personal info updates
- Photo ID
- Biometric scanning
- Insurance-card scanning
- Facility wayfinding
- Scheduling



BOSTON HEALTHCARE KIOSK

A RUGGED, HIGH-BRIGHT KIOSK BUILT TO HANDLE CROWDS AS WELL THE ELEMENT



The new Boston healthcare kiosk is the result of thousands of deployments and millions of patient check-ins. What we learned has made this next generation of our most popular kiosk better in every way.



- Lobby space is prime real estate, so we made sure Boston could be placed against walls, in small spaces or back-to-back with other units
- Front access to all components plus quick-change hardware makes maintenance fast and easy
- A new 19-inch main monitor with available privacy filter enables onscreen signature capture.
- New LED upper-panel option enables low-power backlit signage opportunities.
- The interior features a new electrical layout with a built-in, secured six-outlet strip.
- All Boston ship ready to accept the latest EMV payment technology.

Of course, like all Olea kiosks, Boston is fully ADA-compliant.



A CLOSER LOOK

AT BOSTON HEALTHCARE

STANDARD SPECS

- Complete overhaul for today's most demanding standards
- 19" Projected Capacitive touchscreen with privacy filter
- Expanded internal space for added components and maintenance ease
- Recessed touchscreen for added privacy
- Barcode scanner
- Magnetic card reader
- Electronic signature pad
- Graphic light box
- Speakers
- High-volume cooling fan
- Audio jack

DIMENSIONS

- Width: 23.00"
- Height: 68.50"
- Depth: 20.00"
- Base plate: 23.50"w x 21"D
- Weight: 164lbs.

OPTIONAL COMPONENTS

- Web camera
- LCD monitor for upper signage
- Stainless trackball
- Biometric ID device (fingerprint, iris or palm)
- WiFi or cellular connectivity

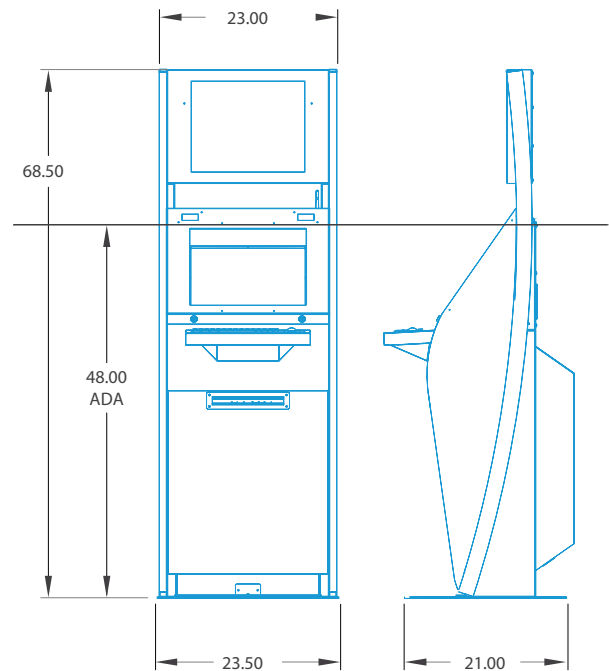

REDEFINING SELF-SERVICE TECHNOLOGY

ABOUT OLEA KIOSKS

CONTINUING A PROUD HERITAGE OF EXCELLENCE

Inspired by a true passion for his craft, master carpenter Fernando Olea began a tradition of bringing his customers' ideas to life back in 1975. He started designing, engineering and producing furniture, cabinetry, display exhibits, commissioned works of art and, later, kiosks in his small, rented RV garage in Downey, California. And Olea was born.

From those humble beginnings to the company's current high-capacity manufacturing facility in Southern California, Olea Kiosks continues to be driven by our founder's innovative spirit, with an old-fashioned commitment to quality, craftsmanship, and service. More than 40 years later our network of 35,000 kiosks registers over 100 million touchpoints per year and we remain a family-owned and operated company. Olea continues to push the limits of kiosk design, using our curiosity and intuition to find new self-service solutions that create a lasting impact for our customers.

AN UNPARALLELED COMMITMENT TO QUALITY AND SERVICE

At Olea, we go beyond producing kiosks that simply meet your technical requirements. We engineer self-service solutions that enhance our clients' brands and complement any space where they are implemented. The following in-house departments work together to consistently deliver attentive customer service and innovative kiosks that comply with our strict quality control guidelines.

- Consulting
- Industrial Design
- Creative Consulting and Graphic Creation
- Mechanical and Structural Engineering
- OEM Manufacturing
- Integration Services
- IT Department (for product testing, computer ghosting services and hardware selection/consulting)
- Powder Coat Painting
- Certification Services
- Patent Services

