

BOSTON KIOSK

DATA SHEET INTERACTIVE KIOSK BUILT FOR PRIVACY

Advertising space in a multi-function, ADA-Compliant

Increase user traffic with this well-rounded and elegantly designed interactive kiosk. The Boston was engineered to address privacy, user comfort and maximize ROI.

The Boston boasts an optional recessed monitor and 3M Privacy Filter that enhances close viewing but deters shoulder surfing. It also makes changing paper a snap with the front service access door.

BRINGING EXCELLENCE TO THE GUEST EXPERIENCE

- Healthcare
- Transactional
- Transportation
- Casino
- Human Resource
- Check-In
- Information
- Government



BOSTON KIOSK

A RUGGED, HIGH-BRIGHT KIOSK BUILT TO HANDLE CROWDS AS WELL THE ELEMENT



Increase user traffic with the well-rounded and elegantly designed Boston Interactive Kiosk. Engineered to address privacy, user comfort and to maximize ROI with a captivating upper graphic light box,



The Boston houses an impressive line of standard components all in a sophisticated and quickly accessible enclosure. This feature-packed kiosk was conceived for user privacy boasting an optional recessed monitor and 3M Privacy Filter that enhances close viewing but deters shoulder surfing.

Configure the Boston with an optional LCD upper monitor to make the most of its advertising features. Olea set out to deliver a dynamic self-service solution and delivered the elegantly private Boston Kiosk.



A CLOSER LOOK

AT BOSTON

STANDARD SPECS

- 19" Wide Viewing Angle Touch Screen
- Amplified Stereo Speakers
- Lighted Sign Panel
- Durable Powder Coat Paint Finish
- 16 Gauge Galvanized Steel
- Dual Security Locks
- High Volume Cooling Fan
- ADA Compliant
- Internal 6-outlet power strip w/ surge protection
- Topple resistant base plate with ability to bolt to ground

DIMENSIONS

- Width: 23.00"
- Height: 68.50"
- Depth: 20.00"
- Base plate: 23.50"w x 21"D
- Weight: 164lbs.

OPTIONAL COMPONENTS

- Dell Optiplex Business Line PC
- Insert or Swipe Style Credit Card Reader
- WiFi or Cellular Connectivity
- Barcode Scanner 1D, 2D, PDF, and QR
- Recessed Monitor for Passive Privacy
- 80mm Thermal Printer (coupon/receipt)
- 8.5" wide Thermal Printer (full sheet)
- 19" Upper Advertising Screen (replaces light box)
- Laminated Side Panels
- Ticket Printer / Laser Printer

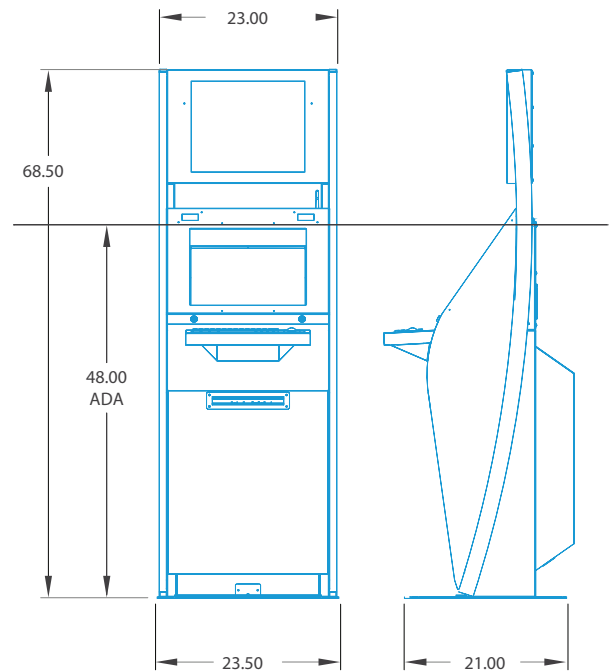

REDEFINING SELF-SERVICE TECHNOLOGY

ABOUT OLEA KIOSKS

CONTINUING A PROUD HERITAGE OF EXCELLENCE

Inspired by a true passion for his craft, master carpenter Fernando Olea began a tradition of bringing his customers' ideas to life back in 1975. He started designing, engineering and producing furniture, cabinetry, display exhibits, commissioned works of art and, later, kiosks in his small, rented RV garage in Downey, California. And Olea was born.

From those humble beginnings to the company's current high-capacity manufacturing facility in Southern California, Olea Kiosks continues to be driven by our founder's innovative spirit, with an old-fashioned commitment to quality, craftsmanship, and service. More than 40 years later our network of 35,000 kiosks registers over 100 million touchpoints per year and we remain a family-owned and operated company. Olea continues to push the limits of kiosk design, using our curiosity and intuition to find new self-service solutions that create a lasting impact for our customers.

AN UNPARALLELED COMMITMENT TO QUALITY AND SERVICE

At Olea, we go beyond producing kiosks that simply meet your technical requirements. We engineer self-service solutions that enhance our clients' brands and complement any space where they are implemented. The following in-house departments work together to consistently deliver attentive customer service and innovative kiosks that comply with our strict quality control guidelines.

- Consulting
- Industrial Design
- Creative Consulting and Graphic Creation
- Mechanical and Structural Engineering
- OEM Manufacturing
- Integration Services
- IT Department (for product testing, computer ghosting services and hardware selection/consulting)
- Powder Coat Painting
- Certification Services
- Patent Services

