

IRVINE KIOSK

DATA SHEET SLIM AND IMPACTFUL

Sleek, intelligent, and deceptively versatile.

The Irvine is a family of kiosks comprised of Freestanding, Countertop, and Wall Mount versions. Originally created for the Fast-Food Industry, it has since become a staple for any application that does not require bulky components such as printers.

While the solution is simple in nature, there are endless different ways to make the Irvine Kiosks your own. Accept Credit Card payment, scan coupons, take photos, and immerse your customers in the brilliant 15" and 22" PCAP Display options. The Irvine is a compact way to introduce self-service into any environment.

STREAMLINE THE CUSTOMER EXPERIENCE.

- Food Ordering
- Ticketing
- Information
- Check-in / Check-out
- Wayfinding
- Virtual Receptionist
- Retail Transactions
- Bill Payment



IRVINE KIOSKS

SLEEK, FRIENDLY. AN INTERACTIVE DIGITAL DISPLAY THAT WILL IMPRESS YOUR GUESTS AS MUCH AS IT HELPS THEM.



The Irvine Kiosks were created in response to requests for something smaller. Not everyone needs a printer, or a bill acceptor, and having a bulky enclosure for no reason just didn't make sense to us.



- The monitor can be ordered in portrait or landscape orientation. Both 15" and 22" PCAP touchscreens are available.
- The body of the kiosk, and the sign panel, can be customized with different colors and decals to advertise your brand or the purpose of using the kiosk.
- Several payment device options are already available and more are added as needed.

With so many existing configurations, the Irvine is used for food ordering, ticketing, healthcare check-in, and more.



A CLOSER LOOK

AT IRVINE KIOSKS

STANDARD SPECS

- 15" or 22" All in One Computer
- Projective capacitive multi-touch touch sensor
- Durable powder coat paint finish
- 16 Gauge Galvanized Steel
- Security Locks
- Internal 6-outlet power strip w/ surge protection
- Topple resistant base plate with ability to bolt to ground

DIMENSIONS

Freestanding

- 16.13"w x 58.10"h x 20.00"d
Base plate: 20.63"w x 20.00"d

Wall Mount

- 16.20"w x 24.70"h x 11.08"d

Desktop

- 17.58"w x 24.89"h x 11.95"d
Base plate: 17.58"w x 9.50"d

OPTIONAL COMPONENTS

- 15" or 22" All in One Multi-Touch Computer (PCAP)
- Ingenico and Verifone payment devices
- Barcode Scanner 1D, 2D, PDF, and QR
- ID Card / loyalty / gift card scanner

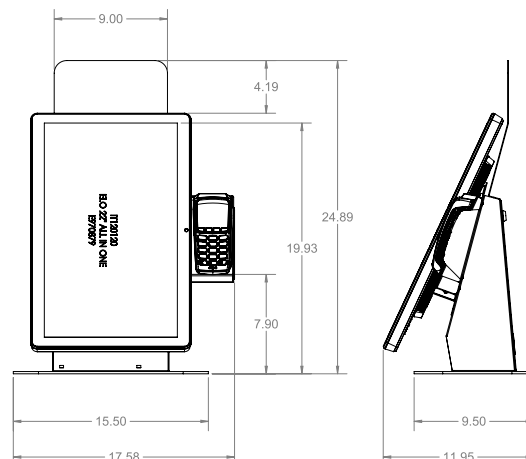
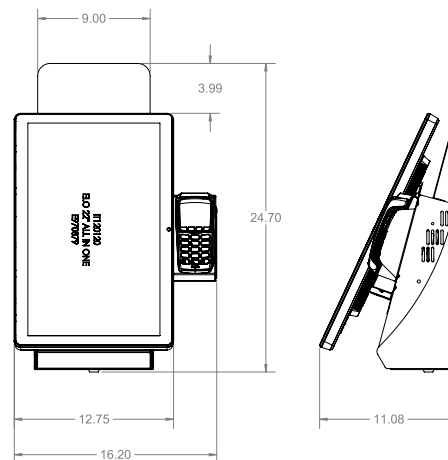
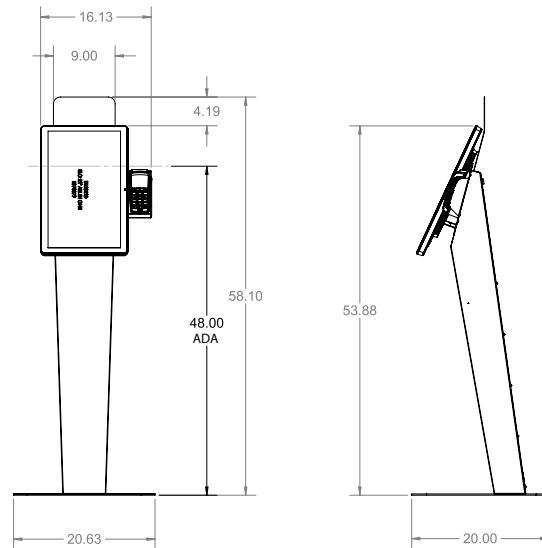

REDEFINING SELF-SERVICE TECHNOLOGY

ABOUT OLEA KIOSKS

CONTINUING A PROUD HERITAGE OF EXCELLENCE

Inspired by a true passion for his craft, master carpenter Fernando Olea began a tradition of bringing his customers' ideas to life back in 1975. He started designing, engineering and producing furniture, cabinetry, display exhibits, commissioned works of art and, later, kiosks in his small, rented RV garage in Downey, California. And Olea was born.

From those humble beginnings to the company's current high-capacity manufacturing facility in Southern California, Olea Kiosks continues to be driven by our founder's innovative spirit, with an old-fashioned commitment to quality, craftsmanship, and service. More than 40 years later our network of 35,000 kiosks registers over 100 million touchpoints per year and we remain a family-owned and operated company. Olea continues to push the limits of kiosk design, using our curiosity and intuition to find new self-service solutions that create a lasting impact for our customers.

AN UNPARALLELED COMMITMENT TO QUALITY AND SERVICE

At Olea, we go beyond producing kiosks that simply meet your technical requirements. We engineer self-service solutions that enhance our clients' brands and complement any space where they are implemented. The following in-house departments work together to consistently deliver attentive customer service and innovative kiosks that comply with our strict quality control guidelines.

- Consulting
- Industrial Design
- Creative Consulting and Graphic Creation
- Mechanical and Structural Engineering
- OEM Manufacturing
- Integration Services
- IT Department (for product testing, computer ghosting services and hardware selection/consulting)
- Powder Coat Painting
- Certification Services
- Patent Services

