

MILAN PORTRAIT KIOSK

DATA SHEET

MODULAR INTERACTIVE DIGITAL SIGNAGE KIOSK

Self-service on a larger scale

Available with four different touch-monitor sizes, the versatile and visually stunning Milan is a superior solution for any facility that needs to inform, direct or influence visitors.

This pedestal-style kiosk was developed for interactive digital signage applications and can accommodate virtually any single or multi-touch LCD monitor, with the option to split the screen for multiple applications, such as retail and wayfinding.

BRINGING EXCELLENCE TO THE GUEST EXPERIENCE

- Retail
- Wayfinding
- Interactive digital signage
- Ticketing
- Virtual receptionist
- Product demonstrations
- Information
- Casino loyalty programs
- Concessions
- Check-in / Check-out



MILAN PORTRAIT KIOSK

SLEEK, FRIENDLY, AND INTERACTIVE DIGITAL DISPLAY THAT WILL IMPRESS YOUR GUESTS AS MUCH AS IT HELPS THEM.

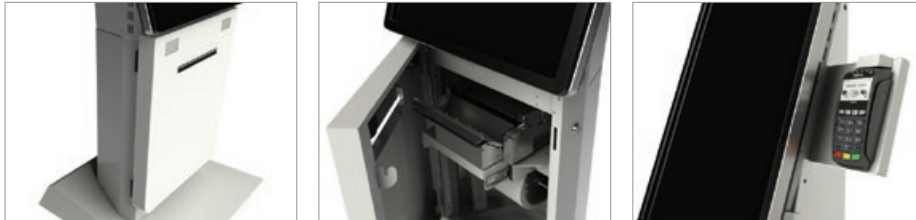

Make an impact with the Milan Landscape Kiosk. This stunning pedestal style kiosk was developed for interactive digital signage applications, but due to its incredible adaptability, the Milan is well suited for a number of other roles, such as wayfinding, Ticketing, virtual receptionist and more.



It features high-grade digital signage monitors built for 24/7, year-round operation. This kiosk can accommodate virtually any single or multi-touch LCD monitor with the option to orient it to portrait or landscape mode.

Because the Milan accommodates larger monitors, it allows deployers to install split-screen application functionality: part of the screen can show images of a product, for example, while another part can display a map to its location in the store.

The Milan can be configured with multiple peripherals, including thermal printers, media players, magnetic and smart card readers, proximity sensors, web cams and QR/barcode scanners.

The Milan. Performance on a pedestal.



A CLOSER LOOK

AT MILAN PORTRAIT

STANDARD SPECS

- 32", 42", 46" or 55" LCD
- Single or multi-touch technology
- Durable powder coat paint finish
- 16 Gauge Galvanized Steel
- Dual security locks
- High-volume cooling fan
- ADA compliant
- Stereo speakers
- Topple-resistant base plate with ability to bolt to ground

DIMENSIONS

- Depth: 32.05"
- Base plate: 40.02"w x 32.05"d
- Weight:
 - Milan 32" Landscape: 137lbs Milan 42" Landscape: 148lbs
 - Milan 46" Landscape: 157lbs. Milan 55" Landscape: 191lbs

OPTIONAL COMPONENTS

- Dell Optiplex Business Line PC
- Elo Integrated Computer Module
- Insert or swipe-style card reader
- Wi-Fi or cellular connection
- Web Camera
- Barcode scanner (1D, 2D, PDF and QR)
- Label printer
- 80mm thermal printer (coupons/receipts)
- Ticket Printer
- 8.5" thermal printer (full page)
- Rear sign panel, with or without printed graphics
- Smaller bolt-down-only base plate

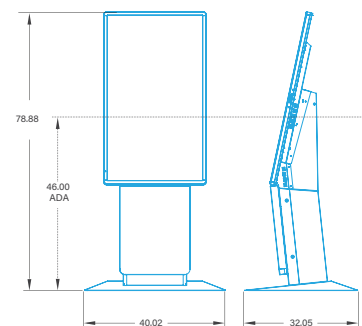
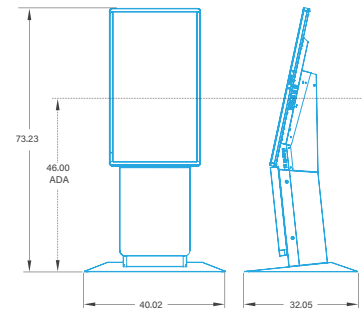
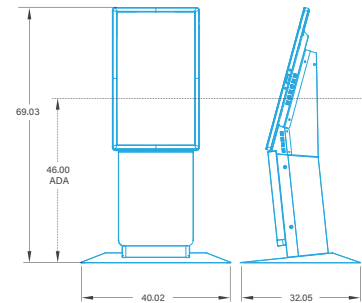
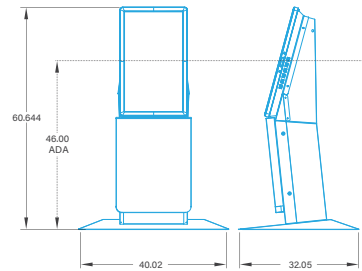

REDEFINING SELF-SERVICE TECHNOLOGY

ABOUT OLEA KIOSKS

CONTINUING A PROUD HERITAGE OF EXCELLENCE

Inspired by a true passion for his craft, master carpenter Fernando Olea began a tradition of bringing his customers' ideas to life back in 1975. He started designing, engineering and producing furniture, cabinetry, display exhibits, commissioned works of art and, later, kiosks in his small, rented RV garage in Downey, California. And Olea was born.

From those humble beginnings to the company's current high-capacity manufacturing facility in Southern California, Olea Kiosks continues to be driven by our founder's innovative spirit, with an old-fashioned commitment to quality, craftsmanship, and service. More than 40 years later our network of 35,000 kiosks registers over 100 million touchpoints per year and we remain a family-owned and operated company. Olea continues to push the limits of kiosk design, using our curiosity and intuition to find new self-service solutions that create a lasting impact for our customers.

AN UNPARALLELED COMMITMENT TO QUALITY AND SERVICE

At Olea, we go beyond producing kiosks that simply meet your technical requirements. We engineer self-service solutions that enhance our clients' brands and complement any space where they are implemented. The following in-house departments work together to consistently deliver attentive customer service and innovative kiosks that comply with our strict quality control guidelines.

- Consulting
- Industrial Design
- Creative Consulting and Graphic Creation
- Mechanical and Structural Engineering
- OEM Manufacturing
- Integration Services
- IT Department (for product testing, computer ghosting services and hardware selection/consulting)
- Powder Coat Painting
- Certification Services
- Patent Services

