

# SEATTLE OUTDOOR KIOSK

## DATA SHEET

### MODULAR INTERACTIVE DIGITAL SIGNAGE KIOSK

*Outdoor where style & functionality get it done.*

Ticketing is a demanding kiosk application. And when the deployment is outside, the need for toughness and visibility is all the greater.

The Seattle is an outdoor kiosk solution with a 19" high-bright touchscreen with rugged components built to withstand hard use in all sorts of weather

Additional capabilities include ticketing, payment acceptance and barcode scanning. Ideal for ticketing, order processing, and crowd-control with line-processing at venues. All Seattle kiosks can be equipped with EMV devices

## BRINGING EXCELLENCE TO THE GUEST EXPERIENCE

- Ticketing
- Concessions
- Pay for Parking
- Casino
- Donations
- Ride Entry
- Wayfinding
- Check-In
- Retail



# THE SEATTLE OUTDOOR KIOSK

A RUGGED, HIGH-BRIGHT KIOSK BUILT TO HANDLE CROWDS AS WELL  
THE ELEMENTS

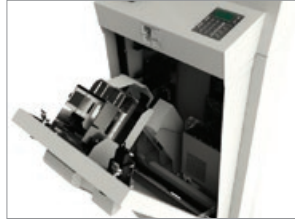

Ticketing is a very demanding kiosk application and when outside, environmental conditions raise the bar even higher.

The Seattle is a stylish outdoor kiosk solution with a 19" high-bright touchscreen with top tier components built to withstand those conditions.

Temperature control systems and IP65-qualified rating makes the Seattle perfect for hot and cold weather deployments.

Capabilities include ticket and wristband printing, payment acceptance including EMV components, and barcode scanning. Ideal for ticket sales, concessions and ride entrance, this solution provides multiple types of access within your property.



# A CLOSER LOOK

## AT SEATTLE OUTDOOR

### STANDARD SPECS

- 19" PCAP High-Bright Outdoor Touchscreen
- Durable powder coat paint finish
- Lightweight, Tough Full Aluminum Construction
- Dual Lock System for Entry Security
- Efficient Solid State Cooling System
- Six-outlet power strip
- Bolt-Down Base Plate

### STANDARD SPECS

- Width: 21.37"
- Height: 57.06"
- Depth: 19.11"
- Base plate: 23"w x 13.34"
- Weight: 142lbs.

### OPTIONAL COMPONENTS

- High-temperature resistant Industrial PC
- Barcode Scanner
- Ticket Printer
- Receipt Printer
- EMV Payment Devices
- Insert Card Reader

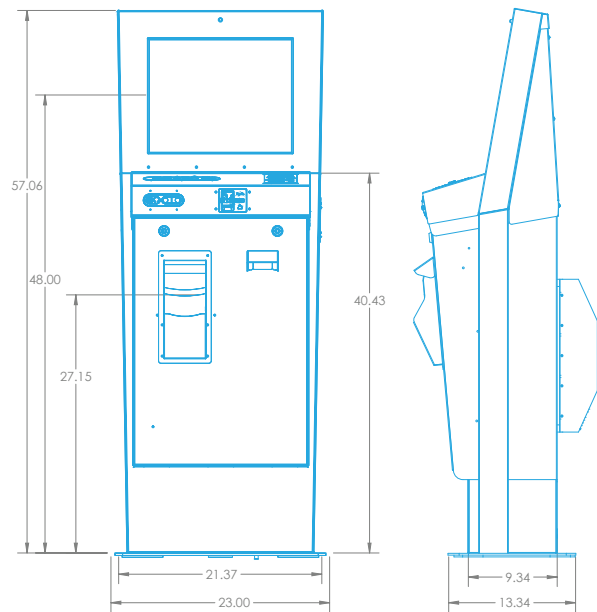

# REDEFINING SELF-SERVICE TECHNOLOGY

## ABOUT OLEA KIOSKS

### CONTINUING A PROUD HERITAGE OF EXCELLENCE

Inspired by a true passion for his craft, master carpenter Fernando Olea began a tradition of bringing his customers' ideas to life back in 1975. He started designing, engineering and producing furniture, cabinetry, display exhibits, commissioned works of art and, later, kiosks in his small, rented RV garage in Downey, California. And Olea was born.

From those humble beginnings to the company's current high-capacity manufacturing facility in Southern California, Olea Kiosks continues to be driven by our founder's innovative spirit, with an old-fashioned commitment to quality, craftsmanship, and service. More than 40 years later our network of 35,000 kiosks registers over 100 million touchpoints per year and we remain a family-owned and operated company. Olea continues to push the limits of kiosk design, using our curiosity and intuition to find new self-service solutions that create a lasting impact for our customers.

### AN UNPARALLELED COMMITMENT TO QUALITY AND SERVICE

At Olea, we go beyond producing kiosks that simply meet your technical requirements. We engineer self-service solutions that enhance our clients' brands and complement any space where they are implemented. The following in-house departments work together to consistently deliver attentive customer service and innovative kiosks that comply with our strict quality control guidelines.

- Consulting
- Industrial Design
- Creative Consulting and Graphic Creation
- Mechanical and Structural Engineering
- OEM Manufacturing
- Integration Services
- IT Department (for product testing, computer ghosting services and hardware selection/consulting)
- Powder Coat Painting
- Certification Services
- Patent Services

