



Austin Temperature Screening Kiosk

CLOUD-BASED, STREAMLINED SCREENING

Get back to work and business safely with the Austin Temperature Screening Kiosk. Designed for businesses with multiple entrances at multiple facilities, this solution will help streamline the screening process and lower labor costs over manual screenings.

This solution is delivered with a base set of features that will provide most organizations with a comprehensive solution to reduce the risk for employees and visitors.

The Austin Temperature Screening Kiosk comes with the following standard features:

- Windows operating system
- Cloud-based management tool for configuration settings
- Access data reporting in secure online portal
- Web-based tool for digital signage, hosting, and support
- Upload branding for customized look
- Ability to print Day Passes—requires a printer
- Ability to run multiple applications simultaneously or re-purpose the kiosk

Optional features available include:

- Real-time text or email alerts notifications for failed screenings
- Customizable health screening questionnaire, delivered on-screen (up to 10 questions, yes or no)
- Access integration with Barcode Scanner or RFID Control systems (requires programming)

Speak with a representative for more information on optional features and pricing.



*Medical testing is necessary to determine presence or absence of infectious disease.

A CLOSER LOOK

SPECIFICATIONS

- Thermal sensor refreshes every 1 second
- Web configurable solution eliminates the need to set-up each unit
- Pass/Fail notification onscreen with optional text alert** and email notifications
- Customizable health screening questionnaire, 10 questions
- Optional barcode badge scanning, supports Honeywell
- RFID, support HID Global Omnikey 5427ck gen 2
- This device meets FDA guidelines for non-medical screening purposes

Speak with a representative for more information on optional features and pricing.

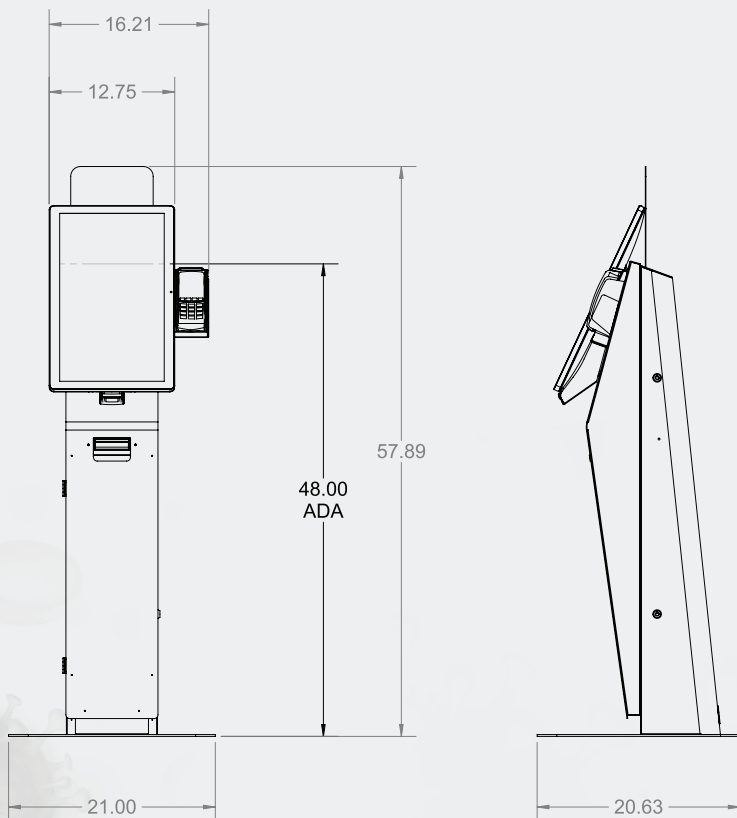

STANDARD SPECS

- 22" Tablet
- Durable powder coat paint finish
- 16 Gauge Galvanized Steel
- Security Locks
- Internal 6-outlet power strip w/ surge protection
- Topple resistant base plate with ability to bolt to ground

DIMENSIONS

Freestanding

- 21" w x 57.89" h x 20.63" d
- Base plate: 21" w x 20.63" d

Olea Kiosks. Redefining Self-Service Technology.

*This solution is designed to detect temperature abnormalities. The IR sensor in the kiosk is measuring the skin surface temperature. There are many factors, including environmental and physiological that can impact a person's surface temperature reading. Skin surface temperature vs. actual core body temperature may differ either way. This temperature screening solution must be operated in accordance with the manufacturer's user guide. It is not intended nor designed to diagnose or detect medical conditions including, but not limited to, viruses or other illnesses. It should only be used to detect variations in surface temperature. If an elevated skin temperature is detected, the subject should be advised to check temperature with an approved medical thermometer as measurement confirmation. Absence of an elevated skin temperature does not preclude a fever. Medical testing is necessary to determine presence or absence of infectious disease. This is not an approved FDA medical device.

**For text alerts, Twilio account required—subscription and per message fees may be applicable..

Re-purpose The Austin Temperature Screening Kiosk

The current pandemic situation suggests that we are going to continue to use temperature screening kiosks to reduce the risk of virus exposure for employees and guests in the near-term, but we all know there is a future beyond Covid-19.

We're prepared to help our customers continue their transition to the future. We've established a solutions marketplace to help our customers re-purpose these kiosks post-pandemic and ensure our customers continue to get value from these kiosks for years to come.

The Austin Temperature Screening kiosk is sleek, intelligent, and deceptively versatile. It provides a number of options for its second life including the following applications:

- Virtual Receptionist
- Wayfinding
- Digital Signage/Information
- Vendor Sign-in
- Guest Sign-in
- Loyalty or Rewards Program
- Retail/Endless Aisle
- QSR/Food Ordering

We have a number of software providers in our marketplace and we continue to grow the list of partners and applications to ensure our customers continue to see value in their self-service technology for years to come.



If you'd like more information about the Austin Temperature Screening Kiosk and the Olea Application Marketplace, please contact us at info@olea.com or visit our website at www.olea.com.